

Towards 5G slicing in Metropolitan Networks: Integrating T-SDN in a NFV context

ElasticNets 3rd Workshop - Tutorial (16:45-17:30)

Ramon Casellas, Ricardo Martínez, Ricard Vilalta and Raúl Muñoz

CTTC, Av. Carl Friedrich Gauss, 7, 08860 Castelldefels, Spain

ramon.casellas@cttc.es © CTTC 2017 All rights reserved



10/19/2017 ElasticNets Workshop Tutorial : Towards 5G slicing in Metropolitan Networks



AENOR
Gestión
I+D+i
UNE-EN 50602
ID:0074/2011

Outline

- ❖ **Introduction and background: Advanced Control plane for Optical networks**
 - Software Defined Networking (SDN)
 - Multi-domain networks
 - Multi-layer networks
- ❖ **The need for (Optical) Network Virtualization**
- ❖ **Abstraction and Control of Traffic Engineered Networks (ACTN)**
 - MDSC, PNC, CNC
 - Example architecture implemented with AS-PCE
- ❖ **Generalizing the concept: 5G-Network Slicing**
 - A suitable framework ETSI NFV
 - Challenges for adoption
 - Metro-Haul Slicing support
- ❖ **Conclusions**



10/19/2017 ElasticNets Workshop Tutorial : Towards 5G slicing in Metropolitan Networks

2

Introduction and Background

Advanced Control Plane for Optical networks



Planes of Operation: Control Plane

❖ Control Plane

- ❑ **Device-wise** Covers the functions used to automate the configuration of the data plane behavior [e.g. forwarding and switching tables], performing resource reservation to ensure QoS; commonly relying on mechanisms, algorithms and protocols for automatic resource and topology discovery.
 - Ex: using a control plane routing protocol, an IP router learns the network topology and destinations and is able to construct forwarding tables in order to forward IP packets efficiently (shortest path).
- ❑ **Network-wise**, the control plane is the system that provides the capability of dynamic provisioning network services (connectivity) between endpoints / terminals.

❖ Do we need a control plane?

❖ It can be argued that a "sufficiently developed management plane" can fulfill the provisioning requirements

- ❑ assuming featured management applications,
- ❑ with flexible management interfaces and adequate device data models,
- ❑ relying on powerful abstractions.

❖ *Historically, the control plane was introduced as a means to **ease the administration** (neighbor, link and topology discovery), favoring a **separation of concerns**, off-loading the management plane and simplifying the service provisioning process, while leveraging the benefits of decentralized routing and control, such as path protection in arbitrary meshed networks, adaptive traffic engineering (routing, load sharing,...) and, notably, having standard interfaces that could enable interoperability -- Now, it remains a functional split, separation of concerns.*



Distributed Control plane

- ❖ Each node has a controller part (control plane entities) which communicates with other controllers
- ❖ We assume there is IP connectivity between controllers
 - IP-based control channels (IPCC) between controllers (need not be physically adjacent)
 - How this IP connectivity is provided is not specified
- ❖ Functions are "distributed", i.e., (in most deployments) each node is responsible for, notably
 - Announcing and managing resources under its control (e.g., its own links), the network view is built in cooperation
 - Computing a path and Triggering the establishment of connections starting in it (upon request)
 - Participating in the signaling of those connections for which it is transit/intermediate node.

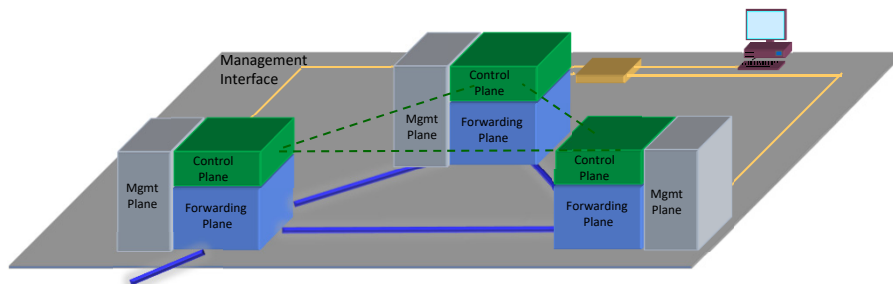

Centralized Control Plane

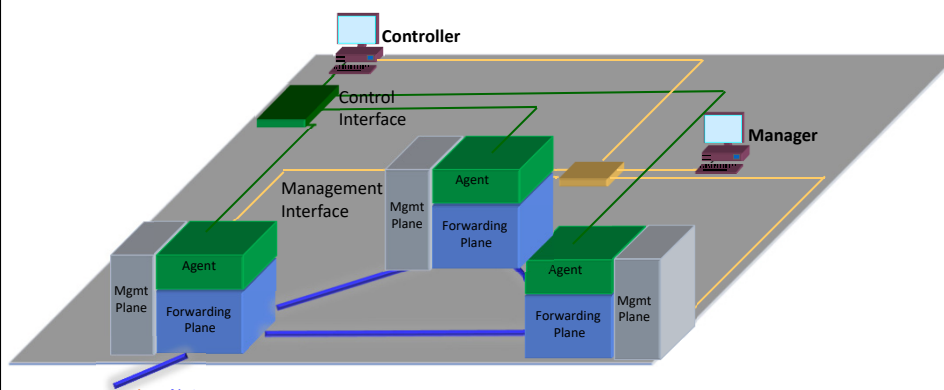

- ❖ Notes:
 - The same physical network may support both control and management interfaces
 - Both the Centralized Controller and the Manager may be collocated
 - The controller itself may have management interface(s)

Distributed or Centralized ?

- ❖ Both have advantages and drawbacks.
- ❖ **CENTRALIZED CONTROL PLANE**
 - ❑ Conceptually simpler. Better integration with operators' OSS/BSS/NMS
 - ❑ No need to synchronize state between nodes, associated convergence times
 - ❑ May present a bottleneck or single point of failure, potential fault-tolerance issues.
 - ❑ Enables parallelized / Non sequential processing of forwarding configurations within a single connection
 - ❑ Single point of deployment of policies, business logic, etc.
 - ❑ Easier to deploy Programming Interfaces (API) enabling extensions
- ❖ **DISTRIBUTED CONTROL PLANE**
 - ❑ Maturity, robustness.
 - ❑ Requires DB synchronization
 - ❑ Implementations usually need to conform to a wider set of protocols
 - ❑ Enables distributed parameter checking
 - ❑ May support higher loads
 - ❑ Enables parallelized / Non sequential processing of connections
 - ❑ May operate independently of the NMS (although it is not the default mode of operation)
 - ❑ Typically closed, hard to extend



10/19/2017

ElasticNets Workshop Tutorial : Towards 5G slicing in Metropolitan Networks

7

Software Defined Networks (SDN)

- ❖ **Simplified view: SDN ~ architecture and protocols around a set of basic concepts**
 - ❑ Separation of the control plane from the data plane,
 - ❑ Centralized control architecture, enabling an application layer
 - Note: neither the "data plane and control plane separation" nor the "centralized" aspect is new in optical transport networks.
 - ❑ Avoid complexity of distributed control planes
 - ❑ Network devices to be programmed using a standard interface (e.g. OpenFlow) enabling and leveraging programmability

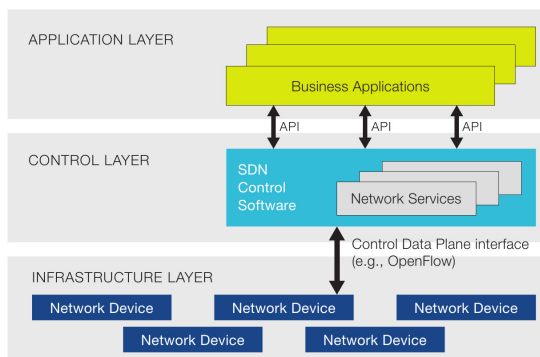

10/19/2017

ElasticNets Workshop Tutorial : Towards 5G slicing in Metropolitan Networks

8

What SDN really implies and allows...

- ❖ **SDN is not just OpenFlow**
- ❖ **Centralizing**
 - Re-visit the centralized model that simplifies network configuration and inventory management,
 - Opportunity for a better integration with OSS / BSS,
 - Better software management and policy deployment / enforcement.
 - Software availability, frameworks, making it easy to innovate via applications that use “system calls” and APIs, without caring about state synchronization.
 - It is **not** just re-implementing distributed control plane logic in a single entity, but about flexibility
 - Easier to integrate in an IT / Network joint over-arching control with resources across multiple domains
- ❖ **Technological constraints**
 - Specifics of the optical technology (continuity constraint, physical impairments, need “à posteriori” path validation...)
 - It is not possible to have a fully featured distributed and **standard** control plane until there is a consensus on the modelling of physical impairments (not likely in a near term)
- ❖ **Computing Trends**
 - Static architecture of conventional networks not adapted to the dynamic computing and storage needs
 - Difficult to implement network-wide policies, need for higher abstractions.
 - The rise of cloud services: Users expect on-demand access to applications, infrastructure, and other IT resources.



What SDN really implies and allows...

- ❖ **Market**
 - Decouple hardware and software, enabling vendor neutral deployments, disaggregation ~ *white-boxes*
 - Exploit the increasing capabilities of hardware to be programmed and configured in different modes.
 - Be able to model the functional behavior of a device regardless of vendor implementation.
 - Arguably, one of the reasons behind the success of OpenFlow is the logical switch abstraction, hiding vendor-specific hardware details, and mapping high level instructions of the protocol, which mitigates inter-operability issues commonly found in multi-vendor deployments, clearly identifying the filter, match, action and similar rules.
 - Push for open and standard models, interfaces and control frameworks.
 - Enable a rich application ecosystem, if possible around open-source frameworks. Exploit APIs and bundle Software Development Kit (SDK). Leverage advances in software engineering.
 - Focusing more on transactional semantics and network/system wide service deployment
- ❖ **New business models**
 - Empower the users to control (virtualized) infrastructure through abstraction in support of multi-tenancy
 - Enable new business around **Network Sharing**, **Network Virtualization**
- ❖ **SDN “Principles” can be broadly applied.**
 - *Specific control plane deployments (e.g. GMPLS/PCE) can be seen as part of a broader SDN-based system.*



What Protocol to Use ? [for South Bound Interface (SBI)]

- ❖ **A single protocol, or multiple protocols depending on the control plane function?**
 - ❑ Should be flexible, extensible, supporting basic functions like “discovery” for topology management, data plane configuration...
 - ❑ It should be future-proof allowing e.g. generic configuration for yet-to-be-invented devices
- ❖ **Byte encoded for efficiency or text based fore ease of use / debugging ...?**
 - ❑ Can I use existing frameworks ? Open Source ?
 - ❑ Should I use XML or JSON given tool availability?
- ❖ **New or build on top of existing protocols and frameworks?**
 - ❑ OpenFlow is stable, fit-for-purpose (notably for packet switched networks), deployed... is it ok for optical networks? Is SNMP expressive enough?
- ❖ **Consider existing solutions, check requirements, perform a gap analysis... (see RFC3535 for SNMP)**
 - ❑ Strong coupling between the device data model(s) [MIB] and the underlying transport protocol (SNMP).
 - ❑ MIB are low level, lack flexibility, and high level constructs.
 - ❑ MIB do not support “operations” (Remote Procedure Calls). A logical operation on a MIB can turn into a sequence of SNMP interactions having to maintain state until the operation is complete, or until a failure. Robust implementations needed (rollback)
 - ❑ Semantic mismatch between the task-oriented view preferred by operators and the data-centric view provided by SNMP. Mapping from a task-oriented to the data-centric view requires non-trivial code on the management application side.



Towards better control and management frameworks...

- ❖ **Ease of use** key requirement from the operators point of view:
 - ❑ Enable operators to concentrate on the configuration of the network as a whole rather than individual devices, supporting network wide configurations.
 - ❑ Agree on common database schema for network configuration.
- ❖ Make a clear **distinction between configuration data, data that describes operational state and statistics.**
 - ❑ Be able to fetch separately configuration data, operational state data, and statistics from devices.
- ❖ Use **Open and standardized interfaces** that support transactions, rollbacks, “operate-as-a-whole”, better abstractions
 - ❑ Along with a modern data modeling language able to express this.
 - ❑ Leverage on the availability of software tools automating common tasks (including versioning, storage, batch processing)
- ❖ See RFC3535 as an in-depth analysis that triggered:
 - ❑ NETCONF WG (2003) Core RFCs (2006),
 - ❑ YANG (RFC6020, 2010).

HUGE ACTIVITY AREA



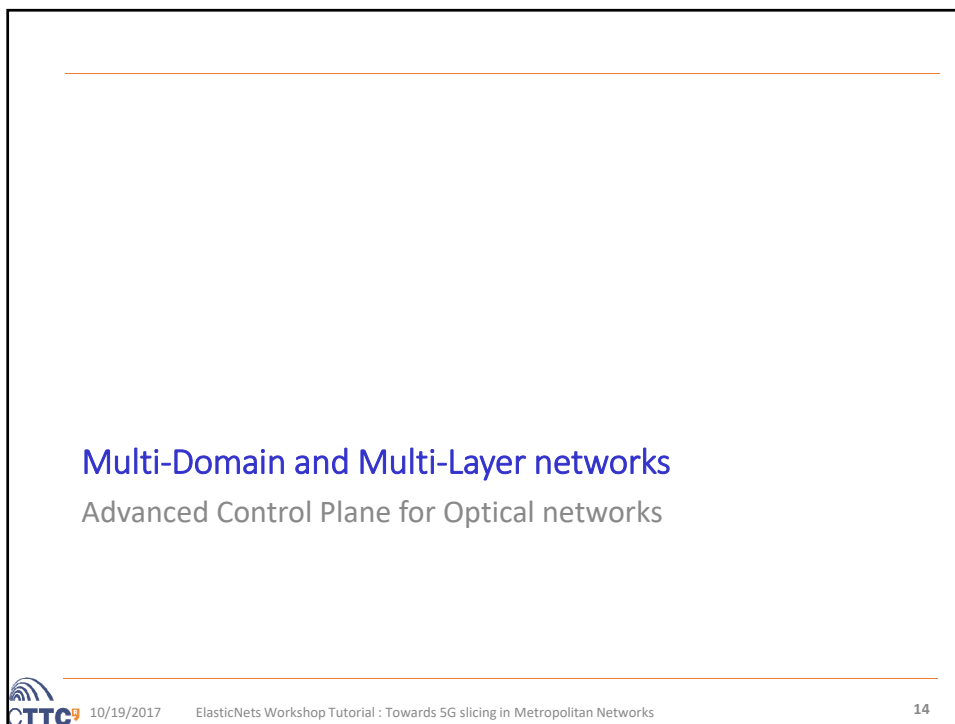
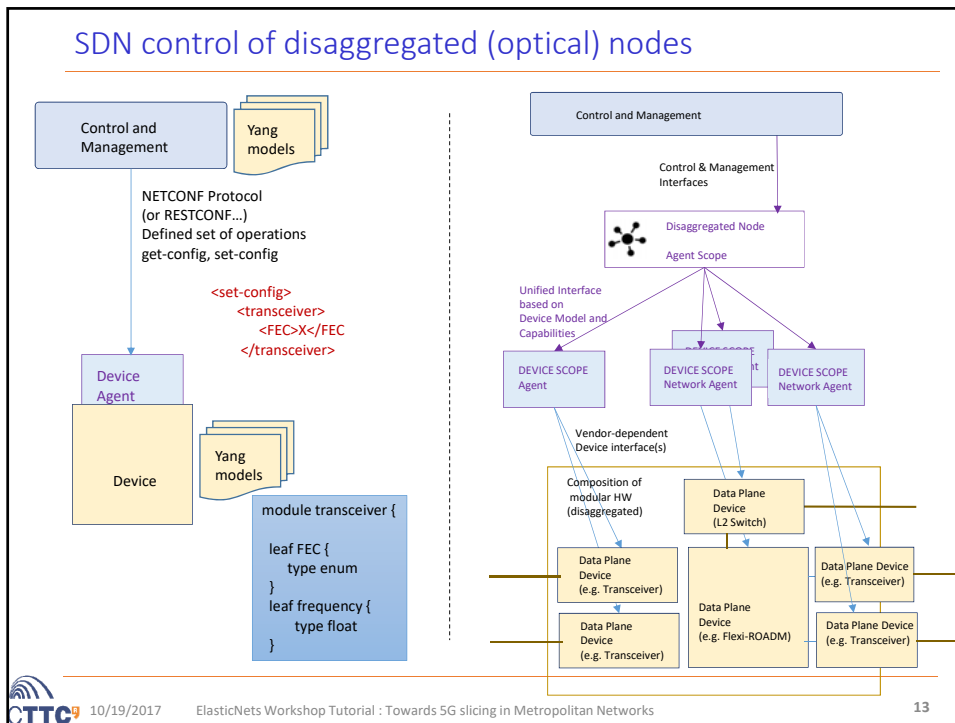

Multi-domain networks

- ❖ **Operators' networks (e.g. MAN / WAN) are segmented in domains**
 - Multiple definitions (context)
 - Can correspond to Traffic Engineering partitions, vendor islands, different technologies, network segments, admin domains, etc.
 - To enhance the scalability and/or for confidentiality reasons, or due to vendor constrains and/or incompatible management interfaces.
- ❖ **Why are multi-domain networks hard? (regardless of the control plane architecture)**
 - Within each domain, the control plane (SDN controller or GMPLS controllers) have a complete view of the topology and resources within their domain and have limited detail of the other domains
 - E.g. exchange of TE/topological information between domains is mostly limited to the dissemination of reachability
 - In specific arrangements, abstracted information.
 - Domains often involve different technologies
 - **Path Computation:** lack of full topology visibility may cause sub-optimal choices, domain local optimality does not imply end to end optimality.
 - **Signaling:**
 - Interoperability issues across domains, trust and security between adjacent domains. Domains may only support SPC or UNI, not E-NNI. Not all interconnection models are realistic.

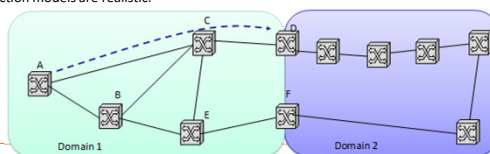

10/19/2017

ElasticNets Workshop Tutorial : Towards 5G slicing in Metropolitan Networks

15

Hierarchical Architectures

- ❖ **Hierarchical PCE (H-PCE) or Hierarchical Arrangement of controllers (H-SDN)**
 - Motivations:
 - Limitations of existing solutions in domain meshes
 - Straightforward approach in SDN solutions in which APIs are consumed in North Bound Interfaces (stacking)
 - A single **parent controller** maintains a domain topology map (aggregated /abstracted topology view)
 - In some cases, this controller is referred to as "network orchestrator or controller of controllers"
 - The map includes the domain inter-connection links
 - Each domain has at least **one controller** capable of computing paths within the domain

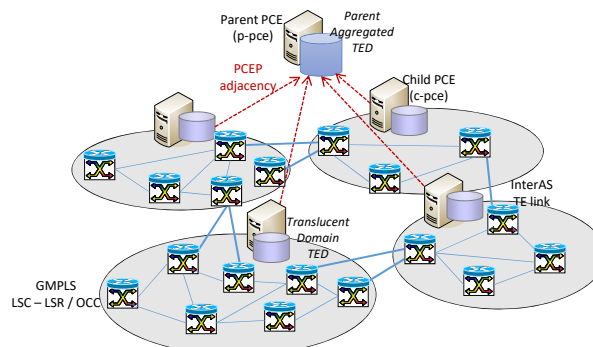

10/19/2017

ElasticNets Workshop Tutorial : Towards 5G slicing in Metropolitan Networks

16

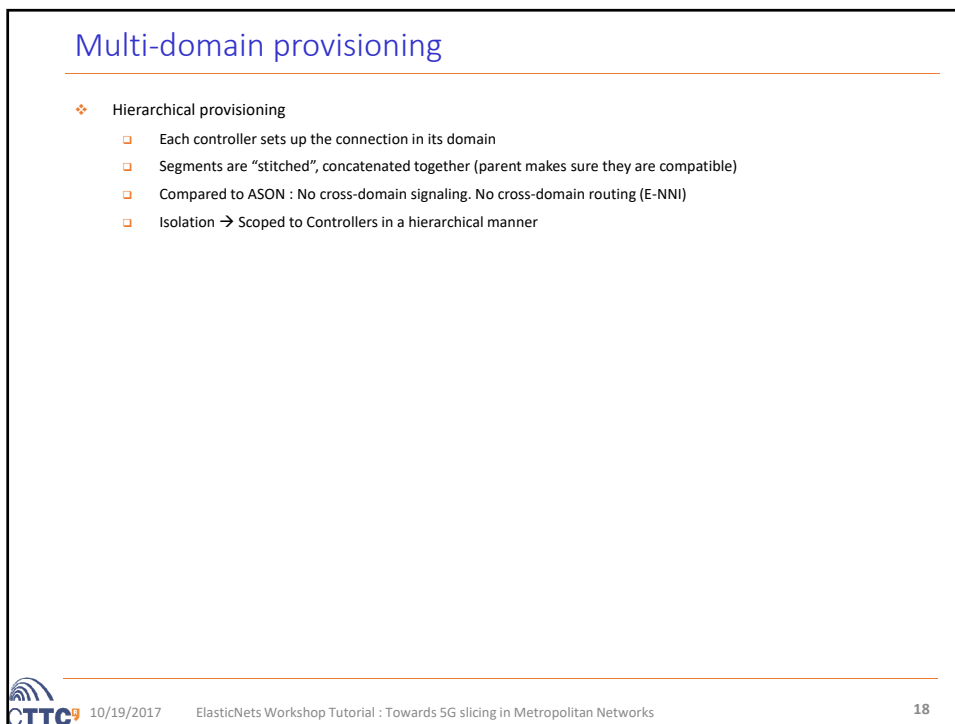
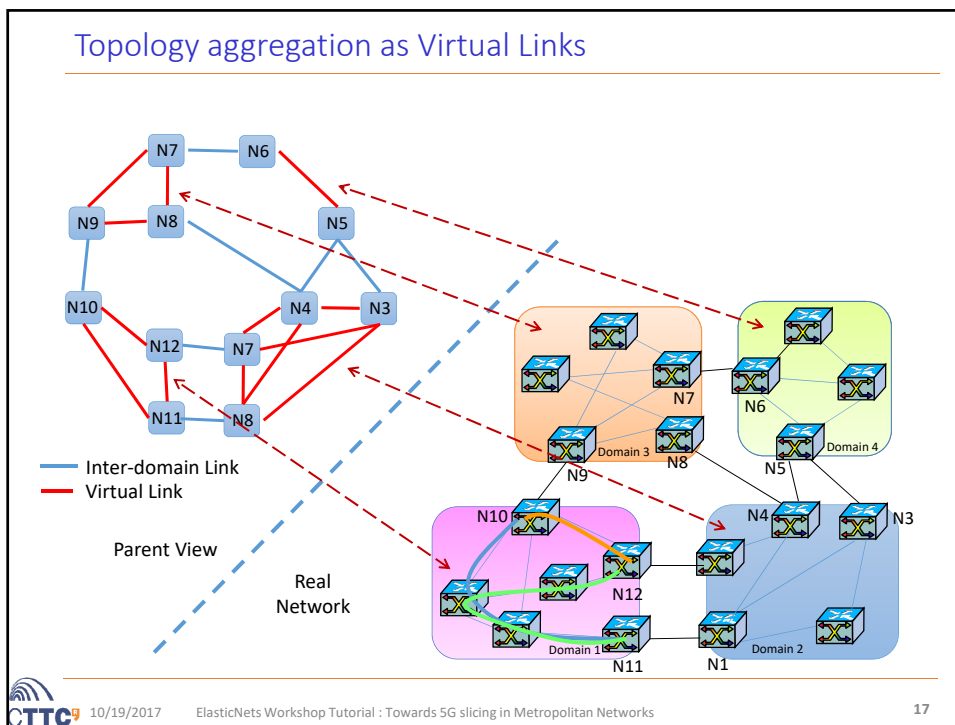

Multi-Layer networks

- ❖ In simple terms, multi-layer networks encompass multiple technologies, such as a packet switched layer and a circuit switched layer, or multiple levels within a given technology (OTN)
- ❖ A multi-layer network is commonly understood within a **client / server model** where a *lower layer (L) connection* is potentially used by *multiple higher layer (H) connections* ~ grooming / multiplexing.
 - ❑ E.g., multiple IP/MPLS packet flows or LSPs can be groomed over a wavelength.
 - ❑ The L-connection becomes a *link* that can be used by the H-layer
 - The link commonly becomes a data plane link but could also support control plane message exchange
- ❖ **Control plane? Feasible?, Interesting? How?**
 - ❑ A **joint control** of multiple layers enables opportunities for efficient resource allocation and provisioning
 - ❑ Conceptually, challenges are similar to multi-domain networks
 - ❑ In particular, having topology visibility of all the involved layers allows optimal path computation.
 - Different levels of topology abstraction → impact on optimality.

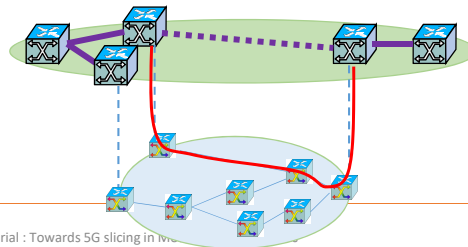

Multi-Layer networks

- ❖ **Can we design a multi-layer control plane?**
 - ❑ A **multi-layer control plane** is a generic term, understood as being able to provision services (with recovery...) across multiple layers.
- ❖ **Approach I:** each layer has its **own Control Plane instance**.
 - ❑ Justified in part due to the fact that the market is segmented (vendors and layers) – *separation of concerns* -
 - Can be the same set of protocols (protocol family) or completely different or a combination of distributed and / or centralized control models.
 - ❑ **Challenges and Issues**
 - **Issue:** *how are both instances coordinated? Can the higher layer use some lower layer information?*
- ❖ **Approach II:** a single control plane instance that knows all the layers
 - ❑ Theoretically optimal
 - ❑ **Challenges and Issues**
 - **Difficult to implement; huge complexity**
- ❖ **In the middle:** optimality is related to visibility of all the involved layers and understanding the implications of all the layers and their relationships.
 - *What topological information is available at the H-layer? Who abstracts it and how is it made available?*
 - *What mechanism triggers the establishment of a L-Conn? How does this connection become a link in H-layer?*

In the SDN world

- ❖ A single instance (e.g. controller) for all switching layers.
 - Full visibility of the regions, operates as a single control domain,
 - Locally separating the technology domains for provisioning purposes.
 - Uses dedicated provisioning interfaces at defined demarcation points.
 - Suitable for small domains

Scalable solutions will need to rely on abstraction and a hybrid combination of centralized and distributed entities.

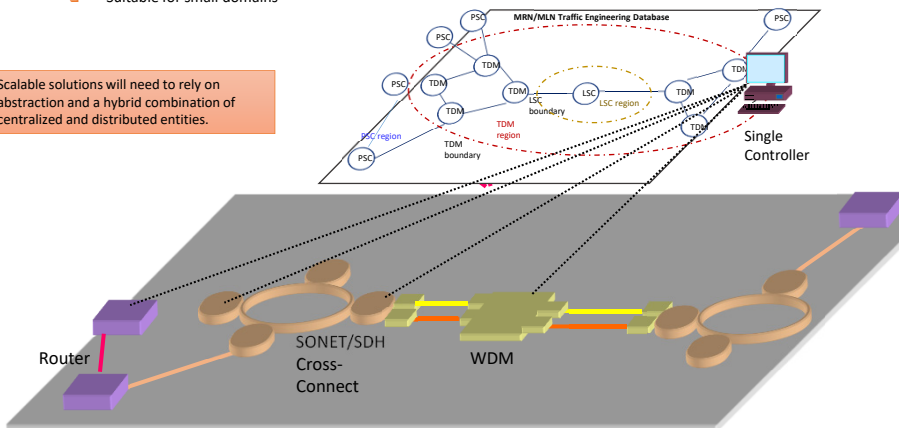

Multi-Layer provisioning: Layered Provisioning

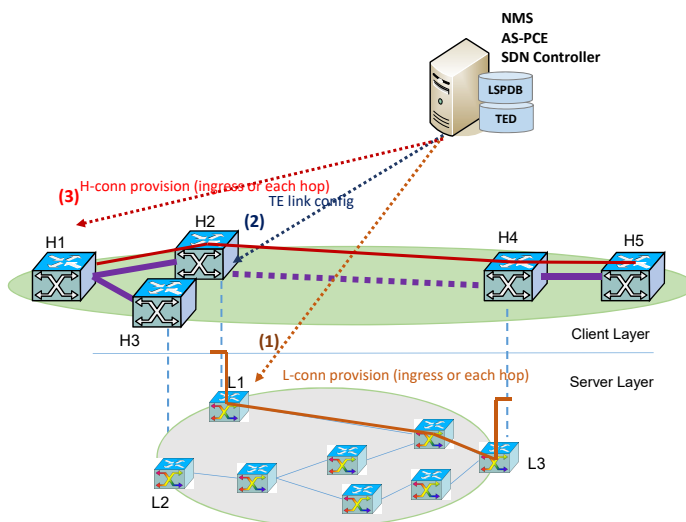

Multi-Layer provisioning: Introducing hierarchy in the CP

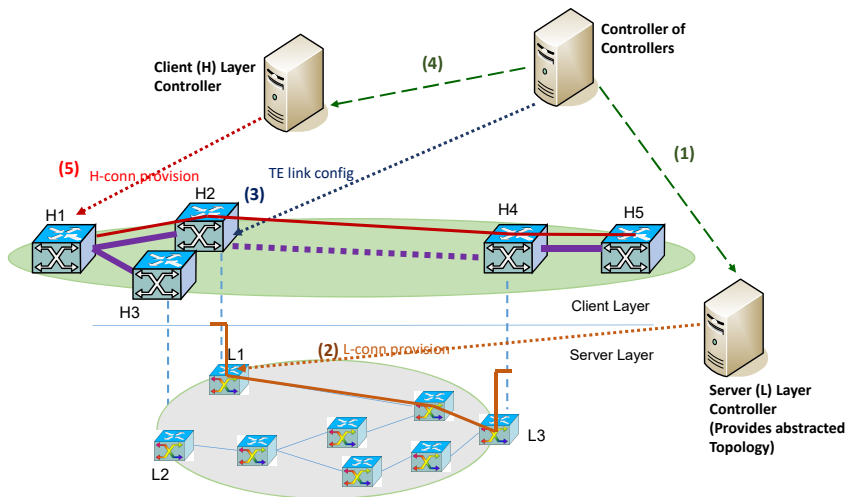

Network Orchestration

- ❖ Need to provision connectivity services across heterogeneous domains (E.g., InterDC connectivity)
- ❖ Need to define domain-abstracted interfaces, under the responsibility of an Orchestrator

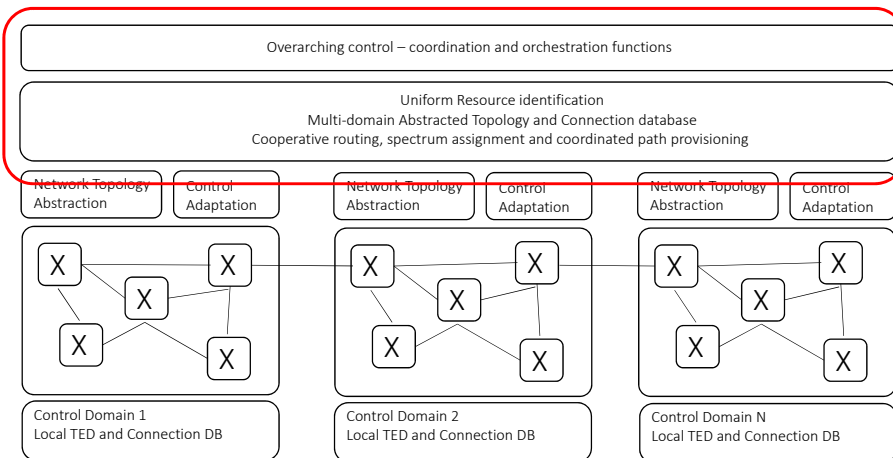

Generalizing the concept...

- ❖ In large deployments, we should consider hybrid models, heterogeneous in terms of protocols and interfaces, combining distributed and centralized models, with peer and hierarchical interconnections.

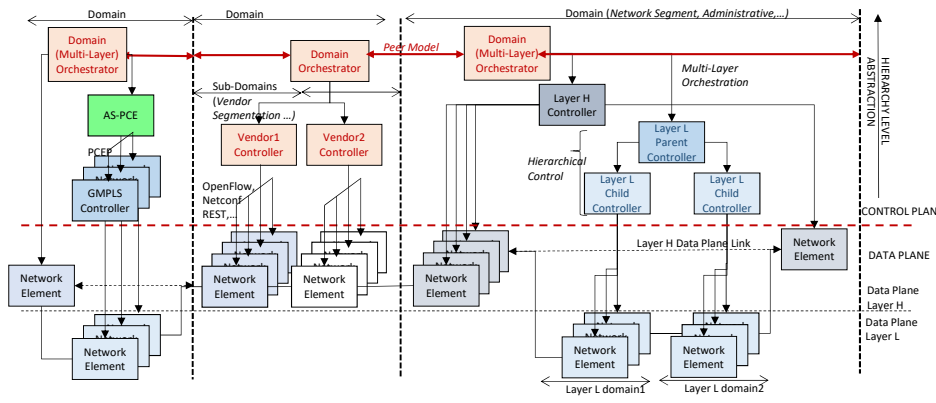

Network Virtualization

Abstraction and Control of Traffic Engineered Networks



Network Virtualization

- **As transport networks evolve, the need to provide network abstraction and virtualization has emerged as a key requirement for operators.**
 - The network is "sliced", with tenants being given a different partial and abstracted topology view of the physical underlying network.
 - Customers and applications (tenants) allowed to utilize and independently control allocated virtual network resources as if resources were real.
- The granularity level of control given to tenants can vary
 - Up to a virtual mesh network topology with dynamic customer control.

Current Control Plane for control of physical network resources, need to be extended to support network virtualization, (by means of e.g. a hypervisor).

Provide open and programmable interfaces, to allocate virtual resources in an interactive, flexible and dynamic way with minimal impact on other tenants.

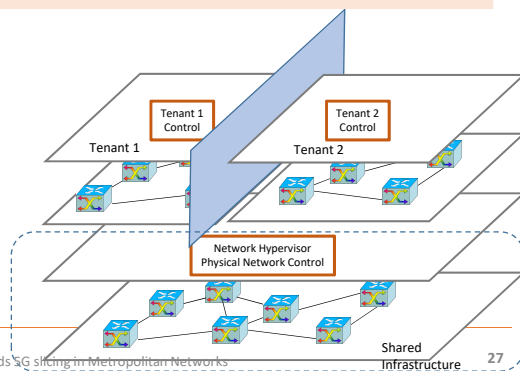

10/19/2017

ElasticNets Workshop Tutorial : Towards 5G slicing in Metropolitan Networks

Shared Infrastructure 27

Abstraction and Control of Traffic Engineered Networks

- A practical approach of T-SDN
 - Enable legacy heterogeneous transport network control/management technologies (e.g., GMPLS/ASON, PCE, NMS/EMS) while allowing new control technologies like SDN OpenFlow controller.
- SDN controllers' hierarchy and roles
 - Customer network controllers (CNC)
 - Multi-domain service coordinators (MDSC)
 - Physical network controllers (PNC)
- Multi-domain service coordination based on abstraction/virtualization.

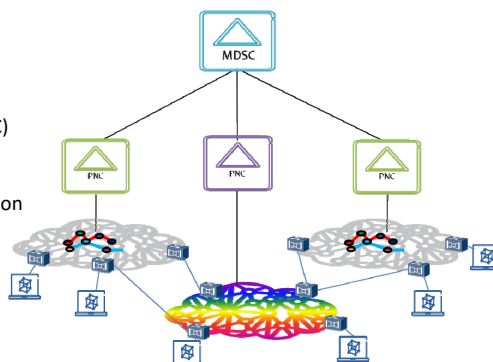

10/19/2017

ElasticNets Workshop Tutorial : Towards 5G slicing in Metropolitan Networks

28

ACTN Deployment in flexi-grid optical networks

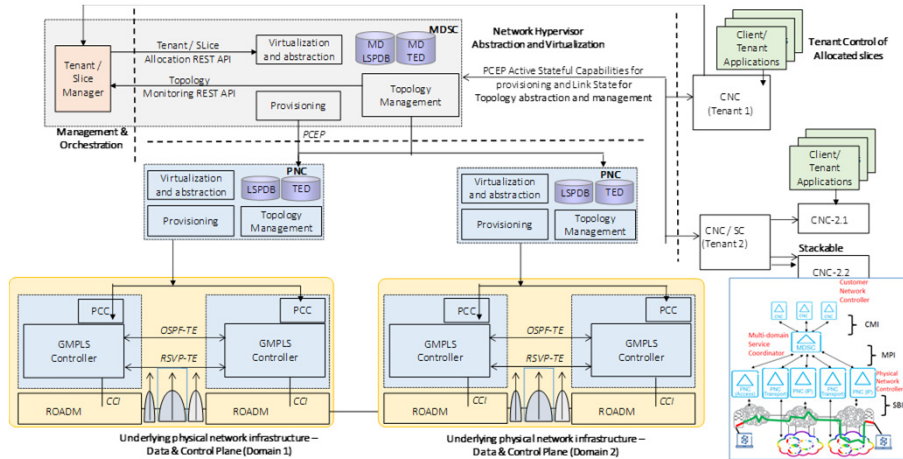

ACTN Deployment in flexi-grid optical networks

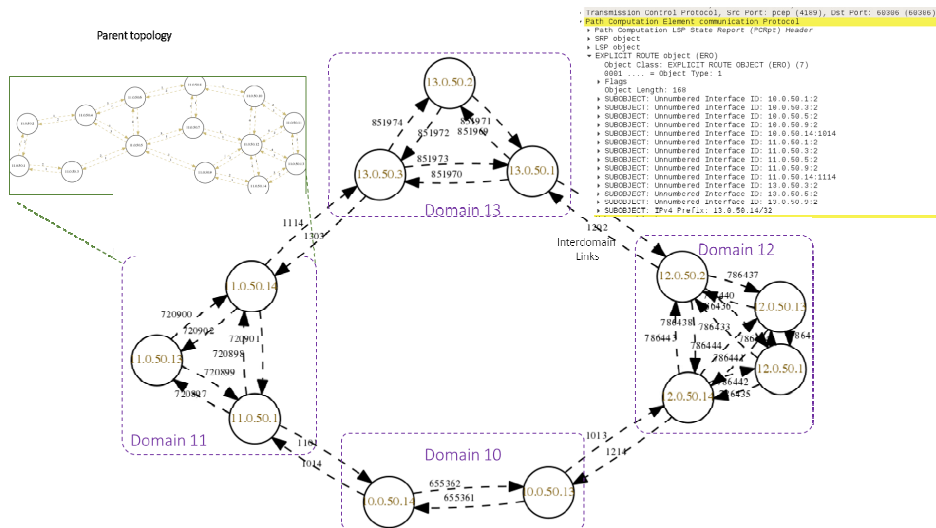

Example with 2 tenants/slices.

```

{
  "id": "tenant1",
  "address": "10.1.6.207",
  "port": 80,
  "nodes": [
    { "nodeid": "110.50.1", "local_ifid": "110.50.1", "ncf_bitmap": "00000001" },
    { "nodeid": "110.50.2", "local_ifid": "110.50.2", "ncf_bitmap": "00000001" },
    { "nodeid": "110.50.3", "local_ifid": "110.50.3", "ncf_bitmap": "00000001" },
    { "nodeid": "110.50.14", "local_ifid": "110.50.14", "ncf_bitmap": "00000001" },
    { "nodeid": "130.50.1", "local_ifid": "130.50.1", "ncf_bitmap": "00000001" },
    { "nodeid": "130.50.2", "local_ifid": "130.50.2", "ncf_bitmap": "00000001" },
    { "nodeid": "130.50.3", "local_ifid": "130.50.3", "ncf_bitmap": "00000001" }
  ],
  "links": [
    { "nodeid": "110.50.1", "local_ifid": "110.50.1", "ncf_bitmap": "00000001", "link": "110.50.1-110.50.2", "channel": "1111111100" },
    { "nodeid": "110.50.2", "local_ifid": "110.50.2", "ncf_bitmap": "00000001", "link": "110.50.2-110.50.3", "channel": "1111111100" },
    { "nodeid": "110.50.3", "local_ifid": "110.50.3", "ncf_bitmap": "00000001", "link": "110.50.3-110.50.1", "channel": "1111111100" },
    { "nodeid": "110.50.14", "local_ifid": "110.50.14", "ncf_bitmap": "00000001", "link": "110.50.14-110.50.1", "channel": "1111111100" },
    { "nodeid": "130.50.1", "local_ifid": "130.50.1", "ncf_bitmap": "00000001", "link": "130.50.1-130.50.2", "channel": "1111111100" },
    { "nodeid": "130.50.2", "local_ifid": "130.50.2", "ncf_bitmap": "00000001", "link": "130.50.2-130.50.3", "channel": "1111111100" },
    { "nodeid": "130.50.3", "local_ifid": "130.50.3", "ncf_bitmap": "00000001", "link": "130.50.3-130.50.1", "channel": "1111111100" }
  ]
}
        
```

Tenant - AS-PCE Controller	Links
tenant1 Nodes: 110.50.1, 110.50.2, 110.50.3, 110.50.14 Links: 110.50.1-110.50.2, 110.50.2-110.50.3, 110.50.3-110.50.1, 110.50.14-110.50.1	Links link: 110.50.1-110.50.2, Channels: 1111111100 link: 110.50.2-110.50.3, Channels: 1111111100 link: 110.50.3-110.50.1, Channels: 1111111100 link: 110.50.14-110.50.1, Channels: 1111111100
tenant2 Nodes: 130.50.1, 130.50.2, 130.50.3 Links: 130.50.1-130.50.2, 130.50.2-130.50.3, 130.50.3-130.50.1	Links link: 130.50.1-130.50.2, Channels: 0000000111 link: 130.50.2-130.50.3, Channels: 0000000111 link: 130.50.3-130.50.1, Channels: 0000000111

CTTC 10/19/2017 ElasticNets Workshop Tutorial : Towards 5G slicing in Metropolitan Networks 31

Example: dynamic instantiation of CNC

```

{
  "id": "customer1",
  "address": "10.1.6.226"
}
        
```

Image Name
pce-utopie-amd64-20150417
pce-utopie-amd64-20150416
centos-0.3.2-x86_64-uec
centos-0.3.2-x86_64-uec-randisk
centos-0.3.2-x86_64-uec-kernel

CTTC 10/19/2017 ElasticNets Workshop Tutorial : Towards 5G slicing in Metropolitan Networks 32

Joint Cloud and Network Orchestration

- ❖ **Network orchestration** → provisioning of connectivity, across heterogeneous domains
- ❖ **Generalizing Orchestration** → Extend the concept to “resource”, regardless of type (network bandwidth, storage resource, computing time, logic function, software process...). Why?
 - ❑ Increased use of virtualized servers;
 - ❑ **New (5G, IoT, ..) services conceived around networking, storage and computing**
 - ❑ Need to provide Inter-VM connectivity.
- ❖ Need for *joint orchestration of compute, storage and network resources*
 - ❑ The “service” provisioning process no longer stops at the physical node → needs to interact with whatever mechanism the hosting nodes (and virtualization hypervisor) offers.
 - ❑ Consider the integration of transport layers across different network segments
 - ❑ Integrated with Cloud Management Systems, ...



Introduction: slicing as an emerging requirement for 5G

- ❖ **Slicing Macroscopic Concept:** partition (slice) a single physical infrastructure into multiple *virtual X* optimized according to specific services, business models, etc.
 - ❑ X? Networks? Infrastructures? Functions?
 - ❑ Network virtualization? Virtual Private Network? ETSI NFV Network Service?
 - All can be seen as a particular cases.
- ❖ **Definitions**
 - ❑ Next Generation Mobile Networks (NGMN) White Paper
 - ❑ 3GPP TR 28.801 V1.0.0 (2017-03) Study on management and orchestration of network slicing for next generation network (Release 14)
 - a set of network functions and the resources for these network functions which are arranged and configured, forming a complete logical network to meet certain network characteristics.
 - May be composed of subnets of Physical Network Functions and/or Virtualized Network Functions.
 - Physical Network Functions and Virtualized Network Functions may belong to one or more network slice subnet(s).
 - ❑ Research papers, White papers...

A logical construct or network, encompassing multiple interconnected functions, customized and optimized for a service (set) or vertical.



A suitable framework: ETSI NFV

❖ What is Networks Function Virtualization (NFV)?

- ❑ In simple terms → architecture and deployment model around the idea of replacing dedicated network appliances — such as routers and firewalls — with software implementations (guests) running on hosts (common hardware)
- ❑ Relies on the concept of host “virtualization”: VMs, containers, etc.

❖ Benefits

- ❑ Lower costs : replacing dedicated appliances with shared servers. Efficient resource usage
- ❑ Reduce operational costs with fewer appliances to deploy and maintain, enable e.g. migrations
- ❑ Support on-demand pay-as-you go deployment models
- ❑ Enable Innovation by making it easier to develop network functions
- ❑ Deploy virtualized solutions on commercial, off-the-shelf (COTS) hardware

❖ ETSI / NFVI architecture

- ❑ NFVI : NFV Infrastructure: support the instantiation of Virtual Machines (VMs)
- ❑ VIM: Virtualized Infrastructure Manager, manages and provides access to storage, network and computer resources (NFVI)
- ❑ MANO : Management and Orchestration , deals with the orchestration of Virtualized Network Functions and how to deploy them (within the so called Network Services)

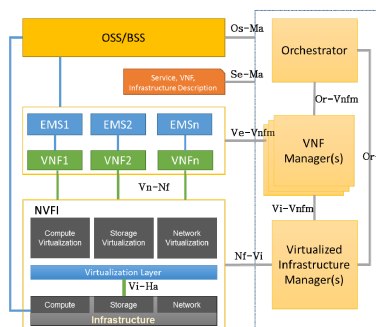

Example Slice: an ETSI / NFV network service

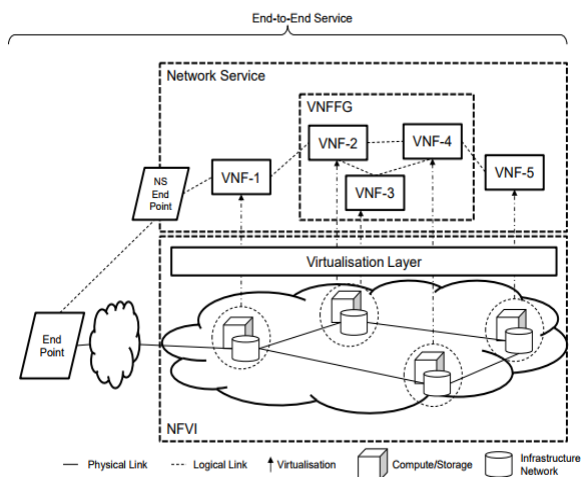
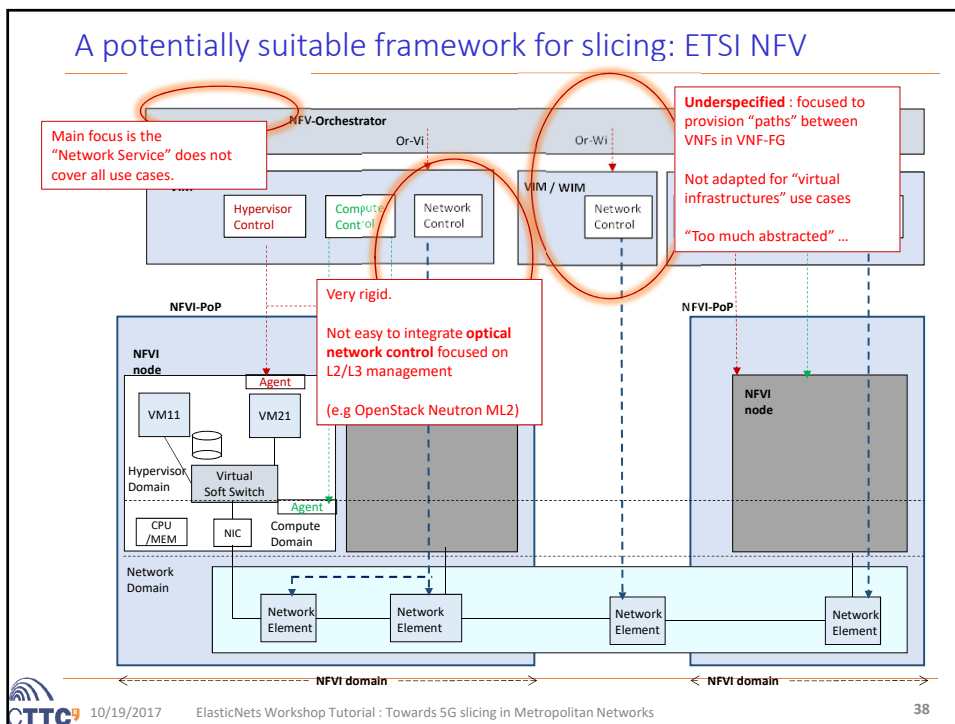
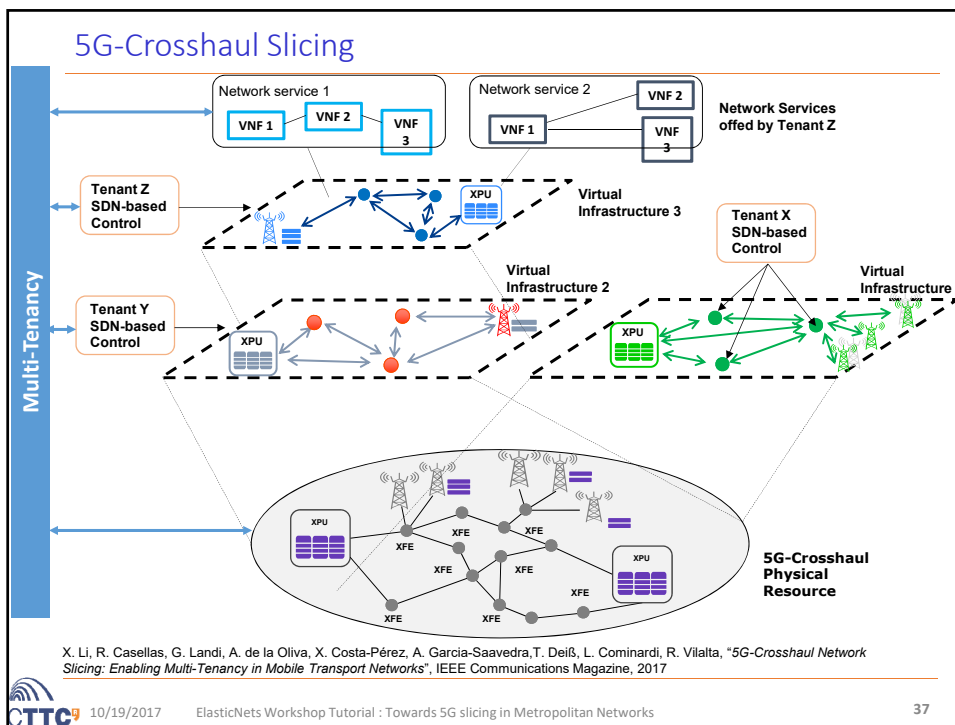

Figure 6.6: Example of a Network Service as part of an end-to-end service with VNFs and a forwarding graph

http://www.etsi.org/deliver/etsi_gs/NFV-MAN/001_099/001/01.01.01_60_gs_NFV-MAN001v010101p.pdf





Metro-Haul macroscopic architecture

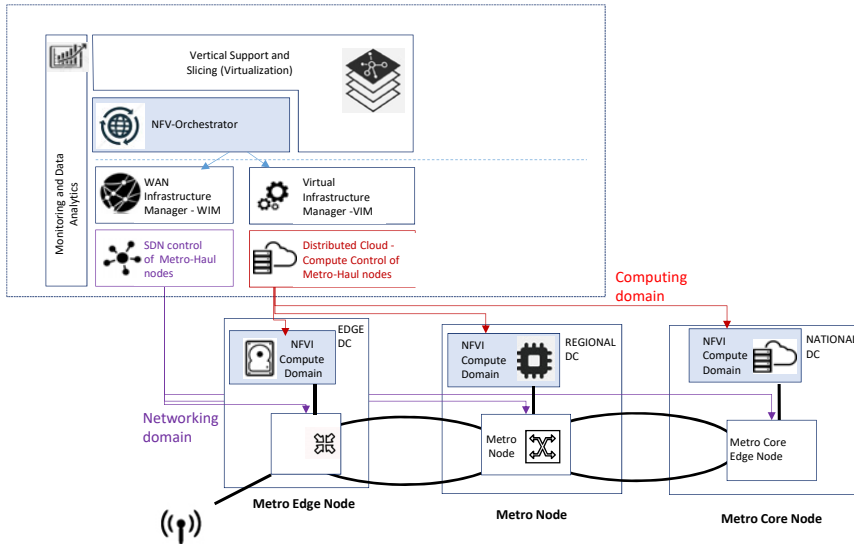

Metro-Haul macroscopic architecture

“Beyond NFVO”
Offer Slicing services in addition to ETSI/NFV NS.
Natively support network virtualization and multi-tenancy.

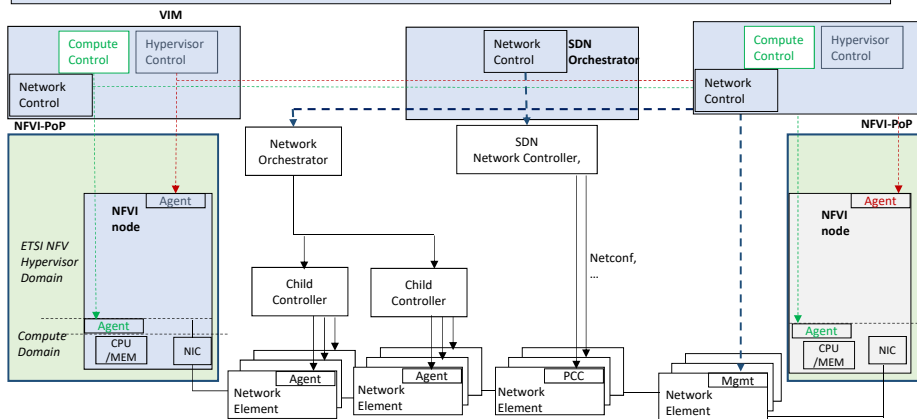

Conclusions

- ❖ Slicing as an emerging requirement for 5G networks; a slice is a *logical construct involving functions and their interconnection, tailored for services and verticals*. The concept somehow generalizes ETSI Network services, virtual networks, VPNs, etc.
- ❖ The ETSI NFV framework, allowing the instantiation of *Network Services*, provides a platform to support network slicing, complemented with a "Slice Manager"
- ❖ Does not fully cover all use cases, specially when partitioning the physical network, allowing ultimate SDN control over the virtual infrastructure
- ❖ **Integrating optical transport networks** and generalizing the slicing concept requires a finer joint orchestration of network and IT resources, with improved visibility of the optical network and its control and management.
- ❖ In particular, we considered the actual partitioning of a multi-domain flexi-grid optical network and how the IETF ACTN and hierarchical Active-Stateful PCE support the concept.



10/19/2017

ElasticNets Workshop Tutorial : Towards 5G slicing in Metropolitan Networks

41



Thank you! Questions?



ramon.casellas@cttc.es
<http://networks.cttc.es/ons>

Work funded by the Spanish Ministry MINECO project DESTELLO (TEC2015-69256-R) and EC through project METRO-HAUL (761727)



10/19/2017

ElasticNets Workshop Tutorial : Towards 5G slicing in Metropolitan Networks

